

---

---

## MOBILE SEISMIC PLATFORM FOR PEOPLE TRAINING

Petrin DRUMEA<sup>1</sup>, Bogdan TUDOR<sup>2</sup>, Stefan TRACHE<sup>3</sup>, Marian SEBE<sup>4</sup>

<sup>1</sup> INOE 2000 - IHP, ihp@fluidas.ro

<sup>2</sup> btudor.ihp@fluidas.ro

<sup>3</sup> "Alexandru Ioan Cuza" Police Academy of Bucharest

<sup>4</sup> Coordinating Centre for Scientific Research in M.A.I., Bucharest

**Abstract:** *The paper have as main purpose the realization of a demonstrator in the form of a platform for 2-4 people, hydraulic operated, for the simulation of the movements felt in the house, induced by the vibrations from the soil as a result of seismic waves generated by earthquakes. About 50% of the population of Romania does not realize how they can be felt in housing, ground vibration created by seismic waves. With no knowledge of this phenomenon, panic among the population can be installed very quickly, emphasizing the effects of an earthquake. At the present time it began to put emphasis on the training of the population, not only on the education and as a result this project will have stages of theoretical training of the population, stages of design, execution and platform experimentation, as well as making some vibrating programs for the platform. All the programs have as basics the typology of the earthquakes in Romania and the national and European normatives about the seismic risks. The platform will be realised in such a way that it can be movable by towing with an automobile and electrically operated by connecting to a public network.*

**Keywords:** *seismic platform, earthquake, seismic activity*

### 1. Introduction

After analyzing people's behavior during and immediately following deployment of an earthquake with a magnitude above 5 on the Richter scale, it was found that usually installs a huge panic, often with tragic consequences. More than half of Romanian citizens have no previous training in relation to earth quakes, no trainind related to situations arising with appearances seismic waves, which is why is installs panic and as a result of misbehaving completed sometimes even deaths. There are statistical data which highlights that over 60 % of deaths could be avoided if people would be trained theoretically and practicaly how to behave on the occurrence and durind the earth quake, there by reducing panic and behavior of a shocked man. Based on these factors, the authors concluded that a simple and relatively cheap solution could be the development and use of mobbille seismic platforms that simulate vibrations that occur in soil and in buildings, notably in housing, for practical training of the population. These platforms can repackage and extend easily, thereby being able to move without problems to schools, kindergartens, residential districts, or wherever there is need for training of the population, regardless of age. These actions are to move from education, most often purely theoretical, to practical training. The earthquake is one of the most terrifying and destructive natural phenomena destructive. Especially since this phenomenon occurs by surprise in any weather conditions at any time of year and day. Therefore, earthquakes have negative psychological effects on people accustomed to regard Earth as a safe support. By the time when everything around us is shaking violently, objects fall, the walls crackle, buildings are collapsing, people are gripped by a terrible fear, after that they hardly recovers. Romania is a country with a high level of seismicity, which requires preparing people to face situations generated by earthquakes, as described above. Preparing the population for awareness of the vibration effects of terrestrial crust on buildings and to protect in the occurrence of an earthquake can reduce people's vulnerability to seismic waves action.

## 2. The situation in the country and on international plan concerning the mobile simulation platforms

Because earthquake risk is found in all countries of the world, the concern of reducing the catastrophic effects of those entered the concerns of policymakers and people from scientific research. The first idea is that earthquakes are inevitable and permanent, second is that are cyclic and third sometimes are catastrophic. If global concern has led to the development of simulation technology platforms earthquakes in Romania have always been attempts at serious unfinished and have not been fully implemented across the country. In countries like Japan and the U.S. have spent huge sums to the development of hydraulically actuated fixed platform by which to simulate earthquakes of different sizes and with which population can be trained to ensure the conduct able to reduce the accident rate. A novelty appeared in recent years, especially in theory is the mobile platform, which is trailed by a car and can be moved into different locations to support the competent authorities in training the population for seismic risk situation. This new concept of mobile platforms lies at the heart of this work, which in turn is part of the population training actions.[1]

**2.1.** In Romania there are not technological processes of manufacturing of mobile platforms, projects and any organized pursuits of practical training on seismic simulators.

There are only attempts and some achievements of studying the behavior of buildings and, possibly, of complex industrial products, at the induction of vibrations using fixed platforms. These platforms from INCERC, INMA, Brasov, Arad, ICPE-EUROTTEST, hydraulic three-axis actuators, were bought from USA, only one of them being assembled in Romania. Attempts of training of the population on fixed platforms, existing (actually just one test), did not give the expected results. The construction of the mobile platform will ease the work of the IGSU specialists to train the young people that follows different schools and other interested person. The proposal from this work it is relevant for the field of population training in the sight of a good behavior in the seismic risk situations, whereas the specialists will have at their hand a simulation equipment which can validate the learning of the theoretical elements as well as the advices regarding the behavior in case of seismic movement over 6 richter degrees. [2]

**2.2.** At international level, there are both vibration fixed and mobile platforms, for population preparedness, but the mobile ones are more for fun, not to prepare people in case of earthquake. The following paragraphs will present some existing solutions worldwide that could be considered as the basis of the concept of platform developed by this project.

Specialists of Indiana Geological Survey realized a mobile earthquake simulator, called Cottage Quake (Figure 1), which can simulate earthquakes of magnitude between 5.5 ÷ 8.0 degrees on Richter Scale.



**Fig. 1.** Cottage Quake  
[<https://igs.indiana.edu/earthquakeexperience/#gsc.tab=0>]



**Fig. 2.** Simulator in Turkey  
[<http://www.turkishairlines.com/en-kz/skylife/haberler/2012/july/akut-ile-deprem-simulasyonu>]

Turkish Security Directorate purchased a mobile earthquake simulator (Figure 2) to inform and prepare the population in case of earthquake.

Another mobile platform is carried out by QuakeHOLD!, called BIG SHAKER (Figure 3). This American platform is capable to simulate earthquakes of magnitude up to 8 degrees on the Richter S

Figures 4 and 5 show two variants of fixed training platforms with kinematic motion quite complex ensured by at least 3 hydraulic axes.



**Fig. 3.** BIG SHAKER

[<http://www.quakeholdindustrial.com/safety-during-earthquakes-safety-preparedness-safety-furniture-straps/Earthquake-Employee-Safety-Training-earthquake-safety.html>]



**Fig. 4.**

[[https://www.mts.com/cs/groups/public/documents/library/dev\\_002251.pdf](https://www.mts.com/cs/groups/public/documents/library/dev_002251.pdf)]



**Fig. 5.** [<http://sunaerosys-co.tistory.com/4>]

### 3. The solution proposed

The solution proposed by the authors consist in realizing a demonstrative model of mobile vibratory platform for population training in the sigh to overcome with calm the fear and the panic appeared in case of an earthquake grather than 4..5 degrees on the Richter scale. The demonstrative model it will be realized in a functional form, capable to train simultaneously a grop of 2 to 4 people snd wil be mouvable into difereent location with the hel of an vehicle towing.

#### 3.1. The concrete performances of the project are the following:

- Realizing a mechanical platform, on which can be placed 2 ÷ 4 people. The length of the platform will be at minimum 2.5 m and a width of about 2 m.
- Making a hydraulic system with one axis, this could provide the vibration of the mechanical mass with 1 ... 35 Hz. The minimum weight of vibrated device, including the platform, will be approximately 1500 kg. Realizing a vibration program that could scan all the frequency range from 1 to 35 Hz, having sinusoidal shape. [3], [4]
- Making of type programs (minimum 10) that can simulate variations of sizes of earthquakes, both on an axis, and two axes

#### 3.2. Structural scheme

The current proposal consist a vibrant table, inducted by one or two axes hydraulic operated, from a sensor block and a electronic computing and comand block. The proposal involves actually a theorethical analyze of the 2 axes variant, according block scheme from figure 6. [5], [6]

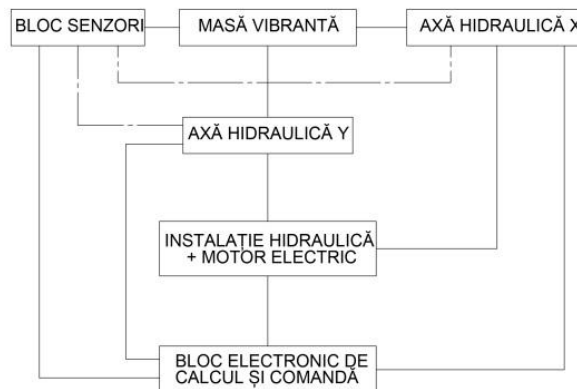

Fig. 6.

### 3.3. Theoretical and experimental elements which underlying proposal

Earthquakes in Romania are due to energetic subcrustal seismic activity of seismogenic area Vrancea and due to numerous seismogenic surface areas, as shown in Figure no. 7, where is presented a map with the seismic hazard of all regions in Romania (source - [www.romaniatv.ro](http://www.romaniatv.ro)).

Fig. 7. [[www.romaniatv.ro](http://www.romaniatv.ro)]

Fig. 8.



Fig. 9.

Vrancea epicenter earthquakes are able to create big problems in over two thirds of Romania. Adding to these facts the surface earthquakes, we can conclude that the majority of Romanian territory is subject to a certain level of seismic risk, amplified in some areas, by the vulnerability of communities. From international studies and statistics on the effects of earthquakes, results that many of the accidents suffered by the population could be avoided if people would know how to proceed in such situations, so, the experts from around the world, including from Romania, they tried to find the most effective training methods on seismic simulators. **The starting concept** is to combine theoretical training of persons with their practical training on a platform of medium size, which can be moved to various places, achieving thus preparing as many persons for emergencies caused by critical situations of earthquakes. In fact, both worldwide and in Romania, started from fixed platforms, mechanically vibrated, completed to test structures, then switched to fixed platforms, hydraulically actuated and, in recent years, it came to mobile platforms for training population, changing somewhat paradigm of seismic vulnerability.

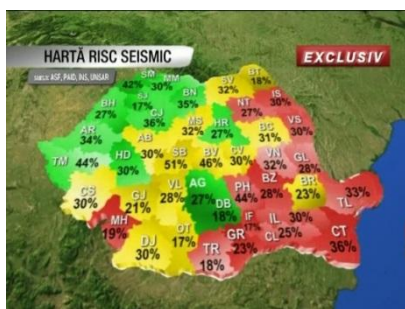
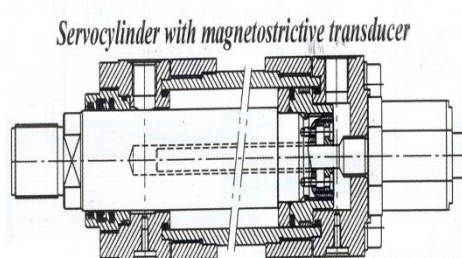
The proposal is based on the type of earthquakes in Romania and surrounding areas as well as from international producers experienced seismic training platforms. Most platforms are hydraulically actuated, having, as a key, hydraulic axis composed of cylinder, servovalve and transducer (Figure 8 and Figure 9). To achieve performance axes, specialists of IHP realized specific studies, mathematical models, including doctor thesis.[7], [8], [9]

The complexity of the project is given, by the diversity of technologies involved in realizing the platform and by the need for knowledge of some elements of sociology and seismology. A general scheme is presented by Nobuyaki Ogawa and his colleagues in Fig. 10.[10]

In order to achieve such a product, need trained specialists from the hydraulics equipments, of the mechanical drives and electrohydraulic adjustments of the mechanics, electronics and computer science field, the disaster prevention field and the psycho-sociological preparedness of population in case of earthquake. Hence, the obligation to use concurrent engineering, as soon as the technical and functional solution for all specialties can and should begin to work, maintaining a permanent link between these groups and an efficient management to correlate of the entire complex. [10], [11]

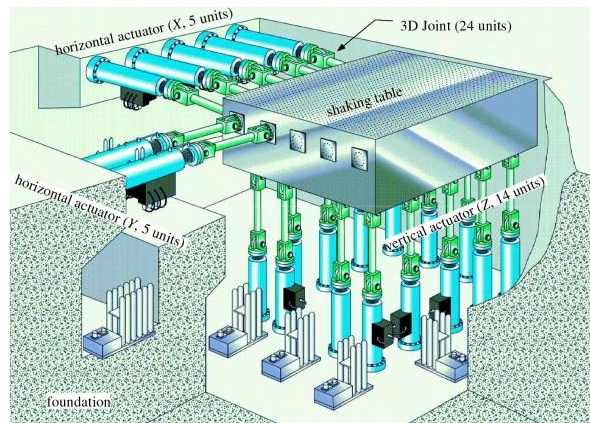

Fig. 10. [10]

#### 4. Conclusions

This work has as basis the experience of the authors in the technical and training population field. The paper takes into account the achievements worldwide in the area of fixed and mobile seismic platforms, two-axis and multi-spindle.

Subject of this paper work formed the basis of a research project proposed under a national scientific research program.

This work is of great interest and possible to be produced at affordable prices by the institutions from which the authors belong.

#### References

- [1] M. Șerban, "Criza și managementul prevenirii și gestionării situațiilor de urgență" ("Crisis prevention and management and emergency management"), Editura Printech, București, 2010, ISBN 978-606-521-603-7;
- [2] Staff IHP, „Actionarea hidraulică a simulatorului de pregătire însoțitor de bord CEETB732 pentru Regional Air Service Tuzla”, ctr no 342 on 13.02.2014;
- [3] D. I. Guta, C. Dumitrescu, I. Lepadatu, C. Cristescu, "Experimental identification of electrohydraulic servomechanisms with virtual instruments technique", Revista HIDRAULICA nr 3/ 2010, ISSN 1453-7303, pp.49-56 BDI: EBSCO;
- [4] C. Cristescu, P. Drumea, D. I. Guta, C. Dumitrescu, P. Krevey, «Theoretical and experimental research regarding the dynamic behaviour of linear hydraulic motors», HIDRAULICA nr. 1-2, 2011, ISSN 1453-7303 , pp.19-34 BDI: EBSCO;
- [5] Al. Marin, I. Cristea, P. Svasta, P. Drumea, "Analysys and synthesis of electrohydraulic servomechanisms", The 2<sup>nd</sup> International Conference on Recent Advances in Mechatronics, Istanbul, Turkey, May 24-26 1999;
- [6] M. Blejan, P. Drumea, M. Comes, "Integration of the Hydraulic Linear Axes in a Computerized System", In 3<sup>rd</sup> International Conference on Innovations, Recent Trends and Challenges in Mechatronics, Mechanical Engineering and New High-Tech Products Development, 22 - 23 September 2011, Bucharest, Romania – MECAHITECH 2011;
- [7] N. Ionita, P. Drumea, G. Matache, M. Comes, "Unitate electrohidraulică de translatie", Source: Proc. of 14<sup>st</sup> International Conference of Hydraulics, Pneumatics, Sealing Elements, Fine Mechanics, Tools, Specific Electronic Equipment & Mechatronics Hervex 2006 ISSN 1454-8003;

- [8] Șt. Trache, et al., „Calculation of the Reactions in Kinematic Coupling for 4R Mechanisms”, Sesiunea Științifică SIGPROT 2013, București 2013, pag. 319-325, ISSN 1844-7805;
- [9] D.V. Cavaropol, M.Șerban, “Studiul statistic al dezastrelor la nivel european si national”, Sesiunea de comunicări științifice cu participare internațională (The statistical study of disasters at European and national Scientific Session with international participation) SIGPROT 2012-2013, editia a XV-a, București 17 mai 2013, pag. 110-116, Ed. MatrixRom București, ISSN 1844-7805;
- [10] N. Ogawa, K. Ohtari, T. Katayoma, H. Shibata, “Construction of a three-dimensional, large-scale shaking table and development of care technology”, National research institute for earth and Disaster Prevention (NIED) Tsukubo, Japan;
- [11] M. Șerban, G. Popescu, “Cutremurele și riscurile generate de acestea” (“Earthquakes and risks arising from these”), Buletinul M. Pompierilor nr.1/2001 Sesiunea științifică SIGPROT 2001, ISSN 1222-1325.