

INFORMATIC TEST BENCH SYSTEM FOR AUTOMOTIVE POWER STEERING

Alexandru HRISTEA¹, Radu RADOI¹, Ion BALAN¹, Dorel GRAB²

¹ INOE 2000-IHP, dumitrescu.ihp@fluidas.ro

² SC Eurotexso Distribution SRL, office@eurotexso.eu

Abstract: The steering system is one of the components that ensure safe movement of vehicles; Besides this, keeping it in optimum condition leads to a minimum fuel consumption but also the lack of pollution associated with working fluid, where assisted hydraulic boxes. Power steering is one of the most requested options in a car of small and medium size, for the vehicles weighing over 1200 kg this is entirely common. In figure 1 is represented the percent's according to the type of assistance steering boxes; from this graph, in conjunction with the average age of the fleet in Romania (12 years in the year 2016), it is deduced that most boxes mounted on cars have hydraulic power steering or electro-hydraulic, so the need for a complex test stand is needed to discover and resolve the problem regarding faults of the system.

This article presents the state of the art test stand for hydraulic power boxes and pumps, with minimal human interference which can determine the current state of the sealing elements, hydraulic directional valves and pump flow. All the records of the oil flow, torque values at the hydraulic directional valve and temperature of the oil are all included in the report generated at the end of the test process.

Keywords: power steering, public safety, automotive

1. Introduction

The basic functionality of the hydraulic power box and components are represented in figure 2. Hydraulic power steering main purpose is that it can provide driver less effort to turn the steered the wheels when driving at typical speeds, and reduce considerably the physical effort necessary to turn the wheels when a vehicle is stopped or moving slowly, is achieved by applying pressure to the sides of a piston rod mounted on a bilateral body (Fig.2); fluid access is made thru an opening after rotary valve 1 mounted on the steering column, receives a response from the pinion 2 always engaging the steering rack rigidly connected to the piston 4. The fluid flows through ducts 3 and 5 represent the body of hydraulic cylinder. (1)

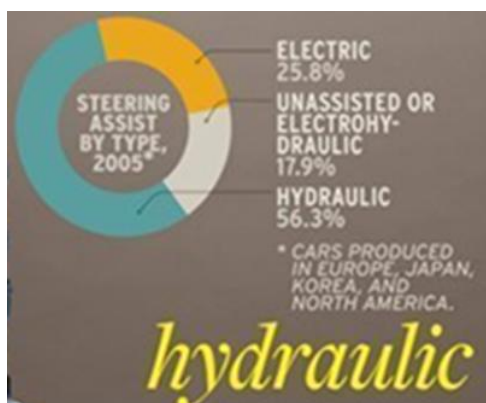

Fig. 1. Percent's of type of assistance

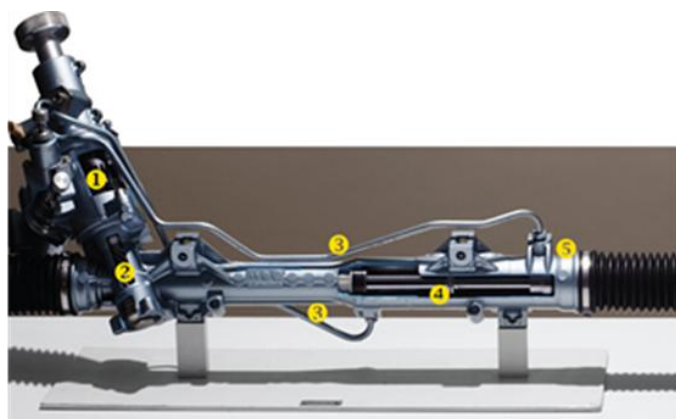

Fig. 2. Hydraulic power steering box

Hydraulic power steering (pump directly driven by the vehicle engine with its rpm) is responsible for fuel consumption of approx. 0.3 l / 100 km; For drive pump by a separate electric motor (electro-hydraulic power steering), that consumption is reduced by half. (2)

However, regardless of version, malfunction is accompanied by an increase in consumption and the loss of oil outside the box, both with negative effects on the environment and road safety.

2. Test stand description

The test bench determines the condition of the seals in the hydraulic distributor of the box and the hydraulic piston by measuring the flow of oil flow during tests [1,2]. The report bulletin contain records such as pressure to each end, handling with predetermined load, oil flow, oil temperature and torque at the hydraulic distributor shaft during handling, series box name operator and company name. The system contains a data acquisition board, pressure transducers, flow, torque, temperature, an actuator and a software application that is needed to perform testing sequences and the registration, storage, processing, a database which will be issued after probation reports that are printed to the printer. All the data recorded is compared with those in the database, the system will decide whether the data recorded for hydraulic steering box comply with the standards accepted by its manufacturer.



Fig. 3. Test bench

1. Load device, 2. Flow meters, 3. 2-way valve, 4. 3-way valve,
5. Pressure gauge, 6. Thermostat, 7. Display for RPM Pump,
8. Power box support, 9. Emergency stop, 10. RPM control

The test stand is composed of several sensors needed to record the parameters which are critical to determine the condition of the steering box. The sensors used in the hydraulically scheme are: pressure sensor with a domain of 0-160 bar (11), flow sensor 0.18-18 l/min (10), rotary encoder needed for the step motor (18), torque sensor 0-500 Nm (17) and a force sensor to determine the force generated by the starting power box of 2000 daN. All the sensors are connected to the data acquisition board (22). In fig.4 it can be seen all the components of the computerized test stand.



Fig. 5. Software control panel

In figure 6 it can be seen a record of the flow of hydraulic fluid lost by steering box at the end of the stroke. If the flow of loss at the end of stroke is above 1.5 l / min is recommended to replace or repair the steering box. A steering box worn, with large internal losses, will lead to disturbance in handling the steering [7].

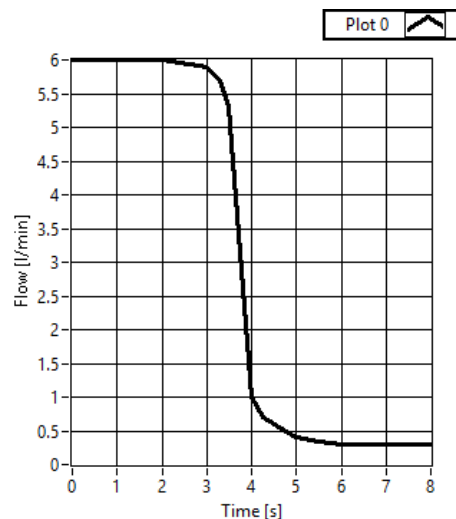

Fig. 6. Flow thru power steering box

In figure 7 it can be seen a record for the pressure raised by the pump of the test bench. After recording the chart of loss of hydraulic fluid for steering box, it can be printed in a report containing identification data from control panel of software and recorded diagram.

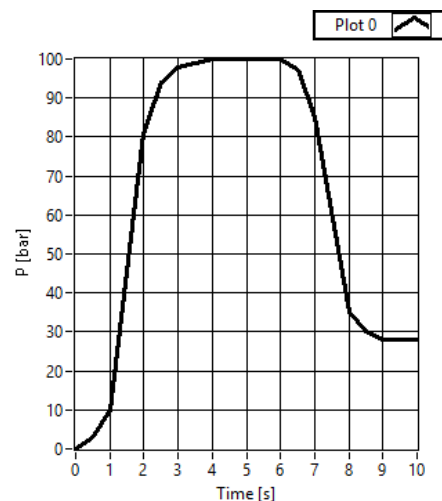

Fig. 7. Pressure from the pump of test bench

4. Conclusions

The test stand equipped with informatic system which registers parameters automatically and issues the report test it have greater accurate results, because almost no human factor interferes. Also the stand is equipped with a thermostatic system for keeping the hydraulic oil to an identical temperature for an identical test condition regardless of the outside temperature.

The amount of sensors and the domain of them, determine how accurate is the report an there for increase the road safety and human loses do to malfunction of hydraulic power steering.

Such a test bench equipped with informatic system is useful for diagnosis of the power steering boxes by automotive service units or for units that performs reconditioning of power steering systems [8].

References

- [1] R.M. Castro, J.M. Neto, Y. M. Moorona, K. Machado, A.S. Rocha, "Development of a Test Bench for analysis of the Supply Pressure Variation in Hydraulic Systems", *Hidraulica Magazine*, No.4/2014, ISSN 2343-7707, pp.7-17;
- [2] A. Mirea, I. Ilie, "Experimental research about dynamic behavior of an electro-hydraulic axis", *Calimanesti-Caciulata, Romania, Proc. Hervex 5-7 November, 2014*, ISSN 1454 - 8003, pp.38-45;
- [3] Marian Blejan, Petrin Drumea, Ioana Ilie - "Mechatronic module for monitoring the hydraulic parameters of industrial equipment", *International Conference 6th Workshop on European Scientific and Industrial Collaboration on promoting Advanced Technologies in Manufacturing WESIC'08 Bucharest, 25-26 September 2008*;
- [4] M. Blejan, B. Lupu - "Data Acquisition and Control Unit for Electro Hydraulic Applications", *ISSE 2009 Conference, Brno, Czech Republic on May 13-17, 2009*;
- [5] M. Blejan, P. Drumea, M. Comes - "Integration of the Hydraulic Linear Axes in a Computerized System" *3rd International Conference on Innovations, Recent Trends and Challenges in Mechatronics, Mechanical Engineering and New High-Tech Products Development, 22 - 23 September 2011, Bucharest, Romania - MECAHITECH 2011*;
- [6] M. Blejan, P. Drumea, M. Comes - "Multi-tier applications for monitoring and controlling of hydraulic axes" *Proc. International Salon of Hydraulics and Pneumatics - HERVEX, 9-11 Nov. Calimanesti-Caciulata, Romania, 2011*, ISSN 1454-8003;
- [7] Drumea, P., Cristescu, C., "Tribology researches on increasing the lifetime of hydraulic components and systems", *Proc. International Scientific-Technical Conference HYDRAULICS AND PNEUMATICS-2012, 16-18th of May 2012, Wroclaw, Poland*;
- [8] <http://eurotexso.eu/> .