

PREDETERMINING THE SIZE OF INRUSH CURRENT IN POWER TRANSFORMERS COUPLING USING LABVIEW

Maria Cristina NIȚU¹, Marian DUȚĂ¹, Claudiu-Ionel NICOLA¹

¹ National Institute for Research, Development and Testing in Electrical Engineering – ICMET Craiova
cristinaniu@icmet.ro, general_manager@icmet.ro, nicolaclaudiu@icmet.ro

Abstract: *Given that the current shock occurring when connecting the transformer at the mains can lead to electrical and mechanical stress in transformer, these can generate failures compromising the reliability of the power system which includes the equipment (the transformer). The project we propose aims to detect the size and time of occurrence of the transient current from the design stage. In order to predetermine the size of the transient current occurring while connecting the power transformer at the mains, a mathematical model of the transformer was achieved and validated through tests (simulations, measurements) for the assessment of the electrical stress in power transformers. The test was carried out on a 15 MVA, 10.5/6.3 kV transformer, based on its magnetization characteristic. The simulations of the phenomenon occurring when connecting the transformer to the mains was carried out using LabVIEW 8.6. The results achieved with simulations are very close to the results achieved through experimental tests performed in the laboratory.*

Keywords: *inrush current, transformer, transient regime, LabVIEW simulation.*

1. Introduction

In recent decades, the use of computers in various fields of activity has become a necessity. From the first design stages and up to the final stage (construction) of a product, the computer has replaced the classic gear. Therefore it was possible to take advantage of effective methods. Genuine virtual prototypes can be created using the computer, with a view to obtaining products which meet the functional requirements on the market. Hence the simulation of the mechanical/electrical systems is carried out until achieving a precise modeling of both system components and of its operating conditions, enabling fast testing of multiple constructive versions, for system optimization [10].

Unlike other power equipment, power transformers are complex oscillating systems, which can undergo failure, for certain forms of voltage, even when the main voltage does not exceed the voltage determined through sizing.

When connecting the transformer to the mains, very high currents develop in the active parts of the transformer, which exceed by much the maximum rating of the steady state current.

The reliability of the power system is a matter of interest, due to the fact that the transformer manufacturer cannot provide information on their behavior when connecting and disconnecting them to/from the mains, therefore it is necessary to ensure their reliability by predetermining the size of the transient current.

In order to limit the consequences of excess transient current, technical solutions are available for implementation in the power system (controlled connection of transformer phases [2]-[4]; fastening the protections at high levels during connection/disconnection) and solutions relating to the design, ensuring an acceptable level of transient current.

Inrush current is a problem, because it interferes with the operation of circuits as they have been designed to function. In a digital world, there is zero tolerance for periods of power failure.

Some effects of high inrush include nuisance fuse or breaker interruptions, as well as arcing and failure of primary circuit components, such as switches. High inrush currents also require oversizing of fuses or breakers, which complicates other aspects of testing approvals and may

compromise protection for other vital components. Another side effect of high inrush is the injection of noise and distortion back into the mains.

Local transformer engineers currently have no custom software to highlight the electrical and/or mechanical stress in case of transitory regime. For this reason we considered developing a program to enable us to predetermine the size of the transient current occurring when connecting the power transformer to the mains [7]-[8].

2. Theoretical concepts

The following is an analysis of the transient phenomena caused by connecting the transformer to the mains, leading to overloads.

It is established that when the transformer running without load, the transformer primary steady state input current is low compared to the rated current, reaching (3-10)% of the rated current [1]. In case of transient regime resulting from closing the circuit-breaker connecting the transformer to the mains, the current can reach up to five times the rated current value.

In order to determine the inrush current, a sinusoidal voltage is applied at the terminals, such as:

$$u_1 = \sqrt{2}U_1 \sin(\omega t + \alpha) \quad (1)$$

where:- $u_1 = \sqrt{2}U_1 \sin \alpha$ - is the voltage applied to the primary at time $t = 0$;

- α - the initial phase angle.

The peak value and the flow of the inrush current depend on the value of the voltage applied at the time of connection (time characterized by α).

The equation for the operation of the primary is [1]:

$$u_1 = r_1 i_{10} + w_1 \frac{d\varphi_1}{dt} \quad (2)$$

- where: - r_1 - primary resistance, i_{10} - inrush current, w_1 - number of turns in the primary, φ_1 - the transformer no-load connection flow (fascicular flow), for simplicity we will consider that this flow passes through all the series turns of the winding and that it is located in the air gap.

The equation (2) can be written as a relation between the inrush current and the flow, with reference to inductance:

$$L_T i_{10} = w_1 \varphi_1 \quad (3)$$

- where: L_T - total inductance, which should be considered variable within certain limits, according to the magnetic saturation of the iron.

The equation of the instantaneous flow is given by the relation:

$$\varphi_1 = \varphi_{1m} \left[\cos \alpha e^{-\frac{t}{\tau}} - \cos(\omega t + \alpha) \right] + \varphi_{1rem} e^{-\frac{t}{\tau}} \quad (4)$$

where:

φ_{1m} - is the maximum flow corresponding to no-load current:

$$\varphi_{1m} = \frac{\sqrt{2}U_1}{\omega w_1} \quad (5)$$

and τ is the winding time constant:

$$\tau = L_T / R_1 \quad (6)$$

The total inductance L_T is the sum of the leakage inductance and the magnetization inductance in the first moments of the coupling.

The resistance R_1 sums up, at the first moment of transformer coupling, the high voltage winding resistance and the resistance equivalent to iron loss.

Since the transformer has not been previously connected to the mains, at time $t=0$ there is no residual flux in the ferromagnetic core, $\varphi_{1rem} = 0$.

It has been established that the most favorable situation from the point of view of the transient regime occurs when $\varphi_{1rem} = 0$ and $\alpha = \pi/2$; in this case the aperiodic component, does not exist, and the instantaneous fascicular flow depends only on the connection current (in a steady state case), and, as a consequence, the most unfavorable situation occurs when $\alpha = 0$ and $\varphi_{1rem} \cong 1/2\varphi_{1m}$. For this situation the transformer is connected when the voltage passes through zero and the residual flux is of opposite sign to the permanent flux.

3. Software application interface developed with LabVIEW

LabVIEW (short for Laboratory Virtual Instrument Engineering Workbench) is a system-design platform and development environment for visual programming language. LabVIEW programs are called virtual instruments, or VIs, because their appearance and operation often imitate physical instruments, such as oscilloscopes and multimeters.

LabVIEW contains a comprehensive set of tools for acquiring, analyzing, displaying, and storing data, as well as tools to help troubleshoot the code [14-15].

The programming language used in LabVIEW, also referred to as G, is a dataflow programming language. Execution is determined by the structure of a graphical block diagram on which the programmer connects different function - nodes by drawing wires. These wires propagate variables and any node can execute as soon as all its input data become available. Since this might be the case for multiple nodes simultaneously, G is inherently capable of parallel execution.

The interface of the application software developed in LabVIEW is presented in Fig.1.

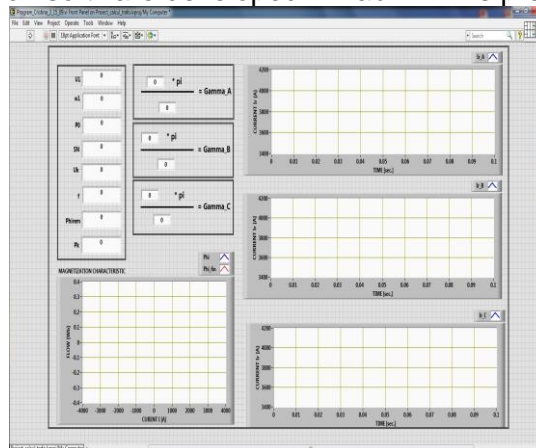

Fig. 1. The software application interface

The software application interface was based on MathScript RT Module included in the Lab VIEW program in order to facilitate data entry and in order to obtain immediate results.

LabVIEW MathScript RT Module adds math-oriented, textual programming to LabVIEW. The MathScript Node offers intuitive means for combining graphical and textual code within LabVIEW; both are currently used in a number of science, engineering and technology programs and industries for simulation and analysis. [11-13].

One of the benefits of working with the MathScript Node is the ability to easily “instrument your algorithms” by using powerful, built-in LabVIEW tools for defining custom interactive user interfaces.

We define inputs and outputs on the MathScript Node border (Fig.2) to specify the data to transfer between the graphical LabVIEW environment and the textual MathScript code.

Fract/Exp String To Number Function (see Fig.3) Interprets the characters 0 through 9, plus, minus, e, E, and the decimal point (usually period) in string starting at offset as a floating-point number in engineering notation, exponential, or fractional format and returns it as a number.

Visual inspection via graphing is essential in analyzing complex data sets. The single-plot XY graph accepts a cluster that contains an x array and a y array. The XY graph also accepts an array

of points, where a point is a cluster that contains an x value and a y value. The bundle function is used to assemble individual elements into a single new cluster.

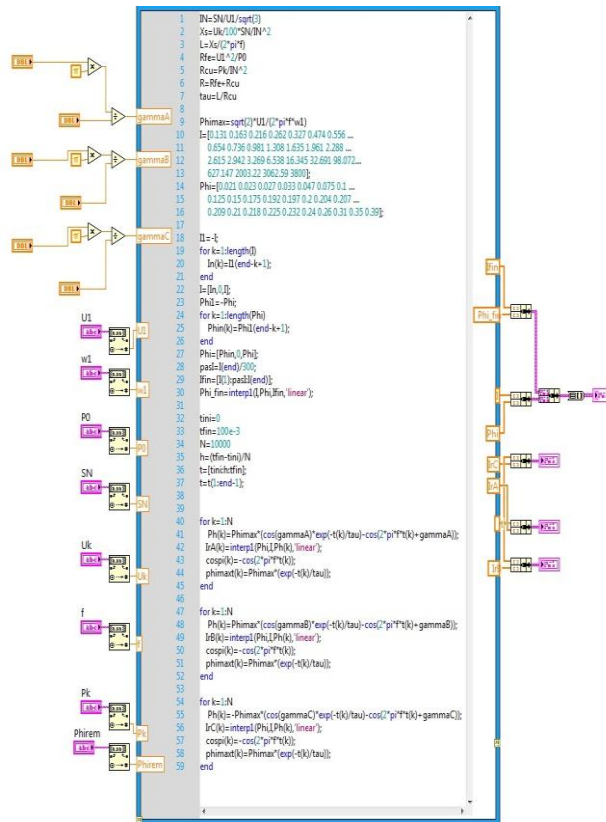

Fig. 2. Block diagram with MathScript Node code

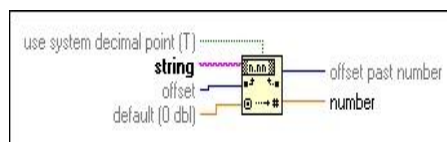

Fig. 3. Numeric conversion function

The waveform for the inrush current on the three phases is accomplished with the functions block from figure 4.

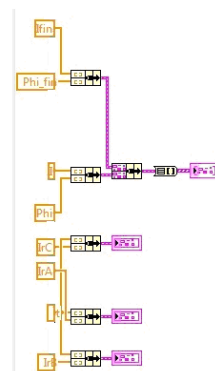

Fig. 4. XY graph of the waveform for inrush current on the three phases

4. Simulation results

To simulate the transient phenomenon occurring when connecting the transformer to the mains, a 15 MVA, 10.5/6.3 kV transformer, with delta/delta connection was used.

The modeling of the phenomenon occurring when connecting the transformer to the mains was achieved using the software application interface developed with LabVIEW software.

By determining the flux values with eq. (4), based on the magnetization curve [5], [6], [7], [8], [9], [10], provided by the producer (Fig.5), we will determine the values of the inrush current.

We achieved a transposition of the magnetization curve, made available by the transformer producing company, instead of its representation according to the magnetic field (H)-magnetic induction (B), we get a representation according to the flow (φ)-current (I)

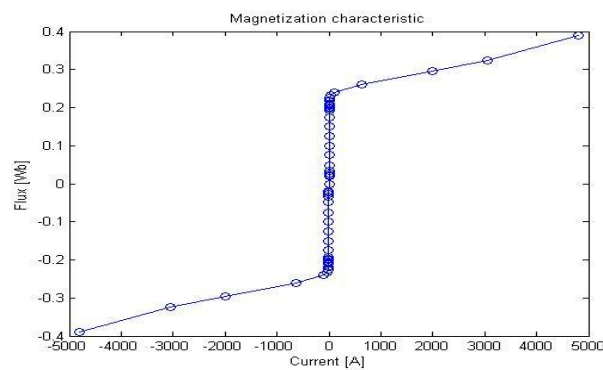

Fig. 5. Magnetization characteristic transposing

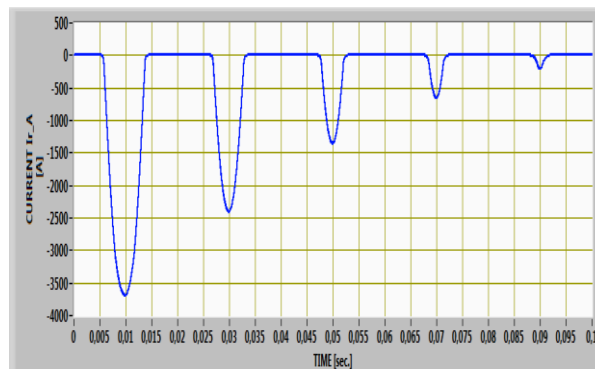

Fig. 6. The waveform for inrush current on phase A, achieved using LabVIEW software

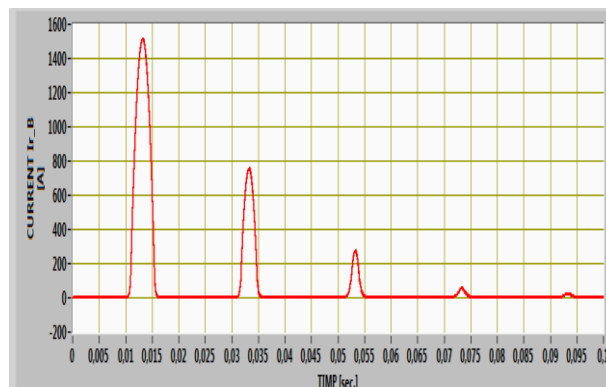

Fig. 7. The waveform for inrush current on phase B achieved using LabVIEW software

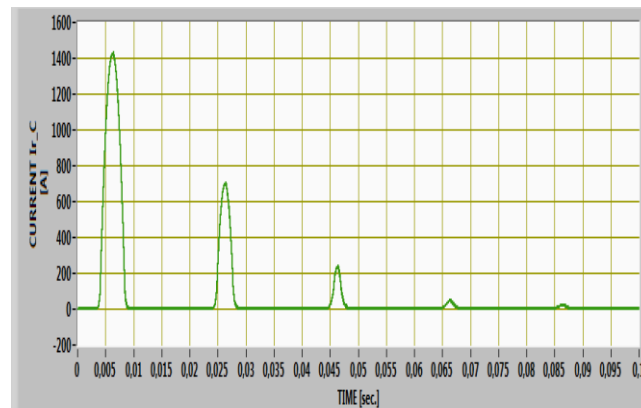

Fig. 8. The waveform for Inrush current on phase C achieved using LabVIEW software

The inrush current reaches the peak value of 3,724 A, on phase A, where the phase angle is zero and the voltage when connecting the transformer to the mains passes through zero (see Fig.6). The inrush current on phase B reaches values of approximately 1,528 A, $\alpha=4\pi/11$ (as in Fig.7). On phase C, the current reaches 1,416 A, $\alpha=2\pi/3$ (see Fig.8).

5. Experimental results

Figure 9 shows the diagram used for testing the transformer when connecting it to the mains.

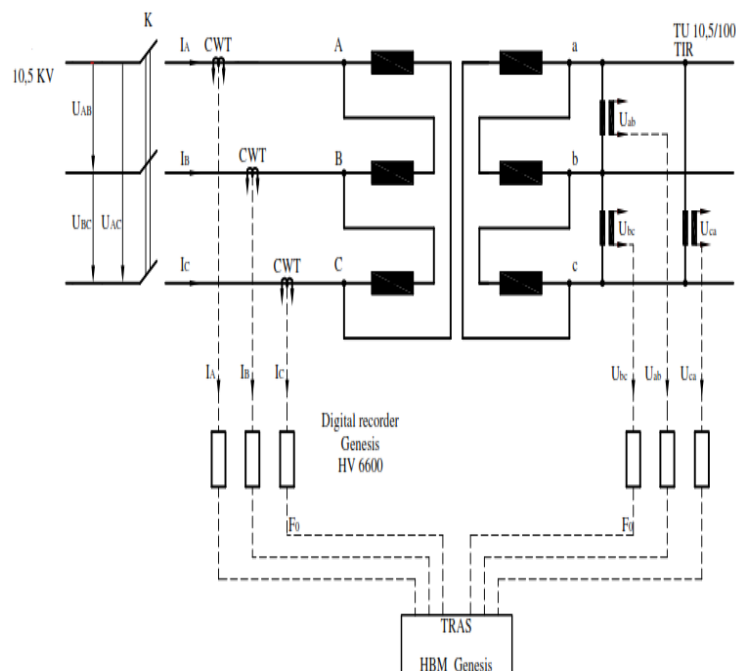

Fig. 9. The transformer testing diagram for the experimental tests

The testing scheme includes instrument voltage transformers, Rogowski coils (CW), equipment for system data recording and acquisition (Digital recorder Genesis HV 6600 TRAS HBM Genesis). Rogowski coils are used for current monitoring in precision systems.

The Genesis High Speed Transient Recorders and Data Acquisition Systems share the highest sample rates and mid to high channel counts. Based on modular platforms, all can be configured according to the requirements of the application, whether a single channel or thousands of channels.

The Genesis High Speed family has signal conditioners for many types of sensors. Many of the modules offer isolated inputs, even for high voltage inputs, allowing safe measurement of phase to phase voltage signals. The sample rates range from 20 kS/s to 100 MS/s per channel. Systems are out-of-the-box and easy-to-use.

The inrush current waveforms were obtained as a result of the test carried out when connecting the transformer to the mains.

Fig. 10 shows the waveforms for voltage and inrush current on phase A: the transformer was connected when the voltage passed through zero and the peak value of the inrush current equals 3,721 A. It can be seen that the peak value occurs at $\alpha = \pi/2$.

The inrush current on phases B and C has a lower value compared to the inrush current value on phase A, 1,524 A current occurs on phase B (as in Fig.11) and 1,407A current on phase C (see Fig.12). This appears due to a different time at the connection.

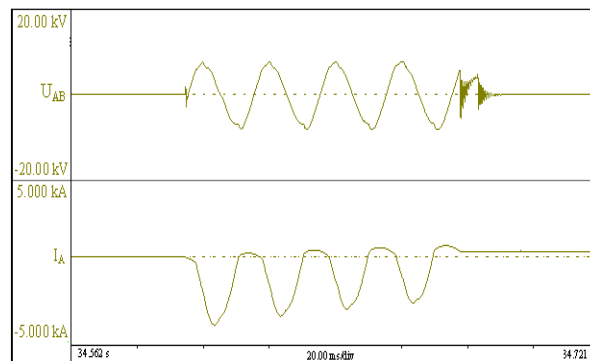

Fig. 10. The waveform for voltage and inrush current on phase A achieved by experimental tests in laboratory

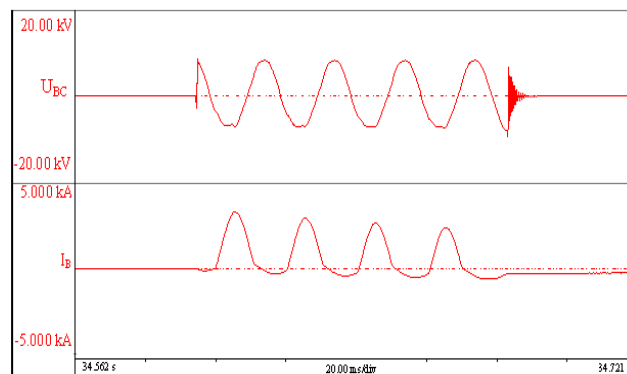

Fig. 11. The waveform for the voltage and inrush current on the phase B achieved by experimental tests in laboratory

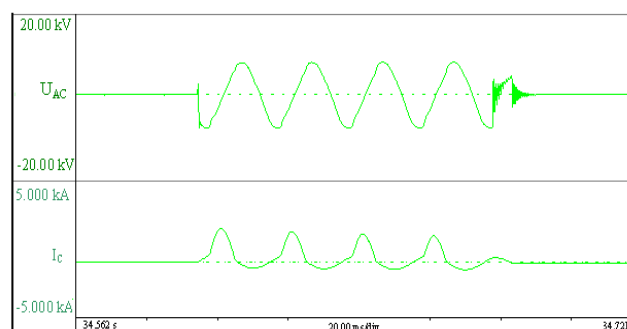

Fig. 12. The waveform for voltage and inrush current on phase C achieved by experimental tests in laboratory

6. Conclusion

In order to limit the consequences of excess transient current, technical solutions are available for implementation in the power system (controlled connection of transformer phases, fastening the protections at high levels during connection / disconnection) and solutions relating to the design, ensuring an acceptable level of transient current.

In this paper we propose to determine the value of the inrush current for adopting suitable protecting equipment.

It can be seen that the transient regime occurring when connecting the transformer to the mains lasts for a few seconds, after which it is damped according to an exponential equation - which depends on the primary resistance and on the flux variation in time.

When coupling the transformer to the terminals of phase A at the initial time, the voltage is close to zero, as well as when the most important shock occurs. This was demonstrated both by simulation of the phenomenon using the software application interface developed with LabVIEW software and by experimental tests.

The value of the inrush current which occurs when the transformer is connected to the mains depends on the time of connection of the transformer to the mains and the initial phase angle.

The mathematical model proposed in this paper can be easily extended for other types of power transformers, to predetermine the size of the inrush current.

There is always a difference between the virtual model adjusted to the phenomenon under study and the actual construction of the transformer due to objective deviations between the transformer design dimensions and real dimensions resulting from its construction.

In the submitted application, the differences noticed are due to inaccurate assessments of the make current damping. This deviation will not affect the use of the virtual model for practical applications focusing on the peak current for protection programming.

Taking into consideration this requirement, the achieved virtual model is more than acceptable. The virtual model can also be used in the transformer design stage when calculating electrodynamic forces occurring in transformer windings which are dependent on the peak current generated when connecting the transformer to the mains.

References

- [1] I.S. Gheorghiu, A.S. Fransua, "Treat on Electric Machines" (in Romanian "Tratat de mașini electrice"), vol. II, Editura A.R.S.R, 1970.
- [2] Yu Cui, Sami G. Abdulsalam, Shiuming Chen, Wilsun Xu, "A sequential phase energization technique for transformer inrush current reduction- Part I: Simulation and experimental results", IEEE Trans. on Power Delivery, vol.20, no.2, pp. 943-949, April 2005.
- [3] Wilsun Xu , Sami G. Abdulsalam, Yu Cui, Xian Liu, , "A sequential phase energization technique for transformer inrush current reduction- Part II- Theoretical analysis and design guide", IEEE Trans. on Power Delivery, vol.20, no.2, pp. 950-957, April 2005.
- [4] Wilsun Xu , Sami G. Abdulsalam, "A sequential phase energization method for transformer inrush current reduction- transient performance and practical considerations", IEEE Trans. on Power Delivery, vol.22, no.1, pp. 208-216, January 2007.
- [5] M.G. Vanti, S.L. Bertoli, S.H.Cabral,, A.G.Gerent, P.Kuo-Peng, "Semianalytic solution for a simple model of inrush currents in transformers ", IEEE Trans. on Magnetics, vol. 44, no.6, June 2008.
- [6] L Mandache, D. Topan, M.Iordache, I.G. Sirbu, "SPICE model for effective and accurate time domain simulation of power transformers", in Proc. of Nonlinear Dynamics and Synchronization (INDS) & 16th Int'l Symposium on Theoretical Electrical Engineering (ISTET), Klagenfurt, pp. 1-6, July 2011
- [7] C.E. Lin, C.L.Cheng, C.L.Huang, J.C.Yeh, "Investigation of magnetizing inrush current in transformers Part I-Numerical Simulation," IEEE Trans. on Power Delivery, vol 8, no.1, pp. 246-253, January 1993
- [8] C.E. Lin, C.L.Cheng, C.L.Huang, J.C.Yeh, "Investigation of magnetizing inrush current in transformers Part II-Harmonic Analysis", IEEE Trans. on Power Delivery, vol 8, no.1, pp. 255-263, January 1993.
- [9] P. Rafajdus, P. Bracinik, V. Hrabovcova, J. Saitz, L.Kankula, "Current transformer analysis under transient conditions, in Proc. of XIX International Conference on Electrical Machines(ICEM), Rome, pp. 1-5, September 2010.

- [10] M. C. Nițu, V. Voicu, M. Duță, P.- M. Nicolae , "Ensuring the Security of the Energy System by Predetermining the Size of Inrush Current at Power Transformers Coupling ",in Proc. of 16th - International Conference on Computer as a Tool- EUROCON, Salamanca, Spain, pp.1-4, September 2015.
- [11] Hans-Petter Halvorsen - LabVIEW MathScript.
- [12] LabVIEW MathScript RT Module.
- [13] LabVIEWTM Basics I Course Manual, March 1998 Edition.
- [14] Abhay W. Rawool, S.V. Kulkarni, P.P. Vaidya, "LabVIEW based electrical partial discharge measurement system", International Journal of Electrical and Electronics Research, vol.3, pp. 76-80, April-June 2015.
- [15] José Aquiles Baesso Grimoni, Osvaldo Shigueru Nakao, " Using LabVIEW in a Mini Power System Model Allowing Remote Access and New Implementations", in Proc. of International Conference on Engineering Education – ICEE, Coimbra, Portugal, , pp.1-5, September 2007.