

## OBTAINING OF PI CONTROL PARAMETERS FOR VECTOR CONTROLLED PMSM

Oğuz EROL<sup>1</sup>, Melih AKTAŞ<sup>2</sup>, Yusuf ALTUN<sup>3</sup>

<sup>1</sup> Duzce University, Engineering Faculty, Mechatronics Engineering, Duzce, Turkey

<sup>2</sup> Duzce University, Engineering Faculty, Electrical and Electronics Engineering, Duzce, Turkey

<sup>3</sup> Duzce University, Engineering Faculty, Computer Engineering, Duzce, Turkey, yusufaltun@duzce.edu.tr

**Abstract:** PMSM motor are getting more common each day in industrial applications due to their superiorities such as lacking physical parts such as brushes or commutators, higher reliability and high efficiency and better life expectancy. Another advantage of a pmsm is that it can operate at speeds above 10,000 rpm in bot loaded and unloaded conditions. It is also capable of operating with less noise and electromagnetic interference than a brushed motor. Only disadvantage of a PMSM is that it needs for a control system which is complex. One of the common ways to control a PMSM is the field oriented control method. PMSM is used for the hydraulic servo motor systems. In this study, a PMSM is controlled with FOC method by using Simulink model and the  $K_p$  and  $K_i$  coefficients of PI have been determined by using Ziegler-Nichols method.

**Keywords:** PMSM, field oriented control, Ziegler-Nichols method, hydraulic servo motor.

### 1. Introduction

The use of PMSM in industrial applications is getting more common each day due to their advantages on other electric motor types. Thanks to rapid development in both power electronics and control systems more and more areas can benefit from the advantages of the PMSM [1]. There are many control methods on PMSM systems for example sliding mode extended state observer (SMESO) technique, an adaptive disturbance compensation finite control set optimal control strategy [2], using linear state feedback controller using the Jacobian linearization [3] or combining Generalized Predictive Control (GPC) with Sliding Mode Disturbance Compensation [4] there are also direct torque control technique which also may include fuzzy logic in the control system [5] but FOC method has significant advantages against the other methods this control method could be applied all kinds of electrical motors by using space vector algorithms [6]. P, PI and PID controllers could be used for speed control in this motor type. Even though PI and PID have simple structures they are widely used in industrial applications. In order to control a system with a PI controller first the controller parameters shall be determined. A good method for determining these parameters is the Ziegler-Nichols method. This method has been used in this paper to speed control a PMSM model in Matlab/Simulink [7].

### 2. PMSM Model and Control

In order to implement our control system on a PMSM model first we need the mathematical model of the motor by using the equivalent motor circuit. The mathematical equations and equivalent circuit of PMSM has been shown below.

$$V_d = R_s i_d + L_d \frac{di_d}{dt} - N \omega i_q L_q, V_q = R_s i_q + L_q \frac{di_q}{dt} + N \omega (i_d L_d + \psi_m) \quad (1)$$

$$V_0 = R_s i_0 + L_0 \frac{di_0}{dt} \quad (2)$$

$$T = \frac{3}{2} N (i_q (i_d L_d + \psi_m) - i_d i_q L_q) \tag{3}$$

where:

$L_d = L_s + M_s + \frac{3}{2} L_m$ ,  $L_d$  is the stator d-axis inductance.

$L_q = L_s + M_s - \frac{3}{2} L_m$ ,  $L_q$  is the stator q-axis inductance.

$L_0 = L_s - 2M_s$ ,  $L_0$  is the stator zero-sequence inductance.

$\omega$  is the rotor mechanical rotational speed.

$N$  is the number of rotor permanent magnet pole pairs.

$T$  is the rotor torque.

dq-abc transform;

$$\begin{bmatrix} a \\ b \\ c \end{bmatrix} = \sqrt{\frac{2}{3}} \begin{bmatrix} \cos \theta & -\sin \theta \\ \cos \theta + 4 \frac{\pi}{3} & -\sin \theta + 4 \frac{\pi}{3} \\ \cos \theta + 2 \frac{\pi}{3} & -\sin \theta + 2 \frac{\pi}{3} \end{bmatrix} \begin{bmatrix} d \\ q \end{bmatrix} \tag{4}$$

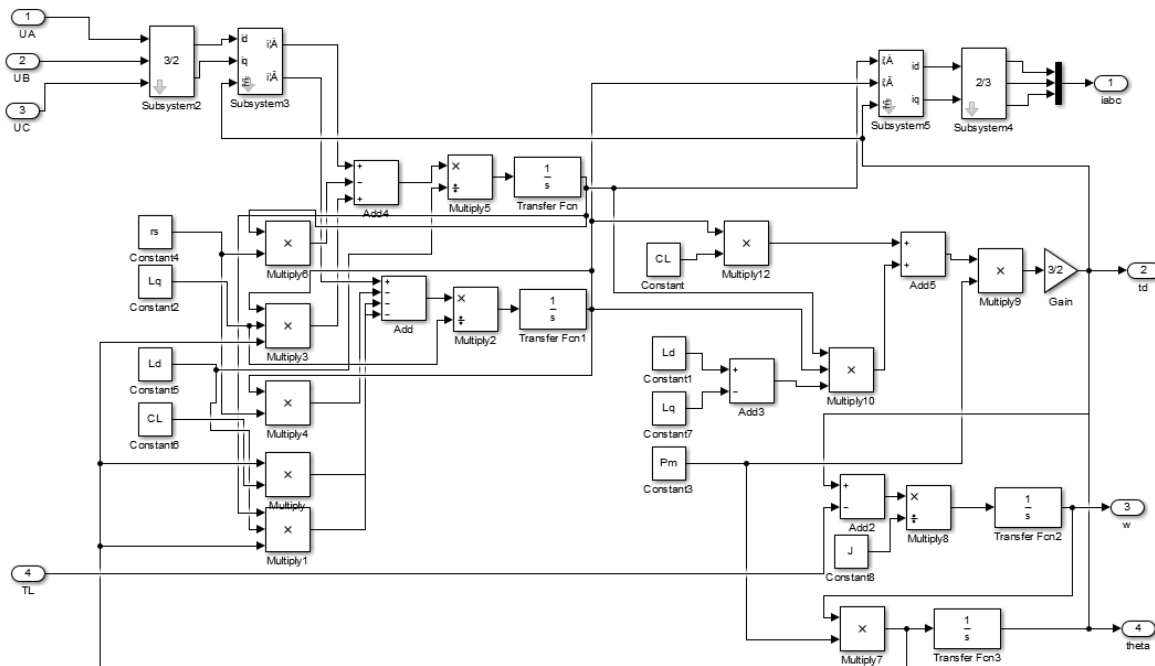

Fig. 1. PMSM Simulink Model Block

The Field Orientated Control (FOC) consists of controlling the stator currents represented by a vector. This control is based on projections which transform a three phase time and speed dependent system into a two co-ordinate (d and q co-ordinates) time invariant system. These projections lead to a structure similar to a DC machine control. Field orientated controlled machines need two constants as input references: the torque component (aligned with the q co-ordinate) and the flux component (aligned with d co-ordinate). As Field Orientated Control is simply based on projections the control structure handles instantaneous electrical quantities [8]. This

makes the control accurate in every working operation (steady state and transient) and independent of the limited bandwidth mathematical model. The FOC thus solves the classic scheme problems [9] [10].

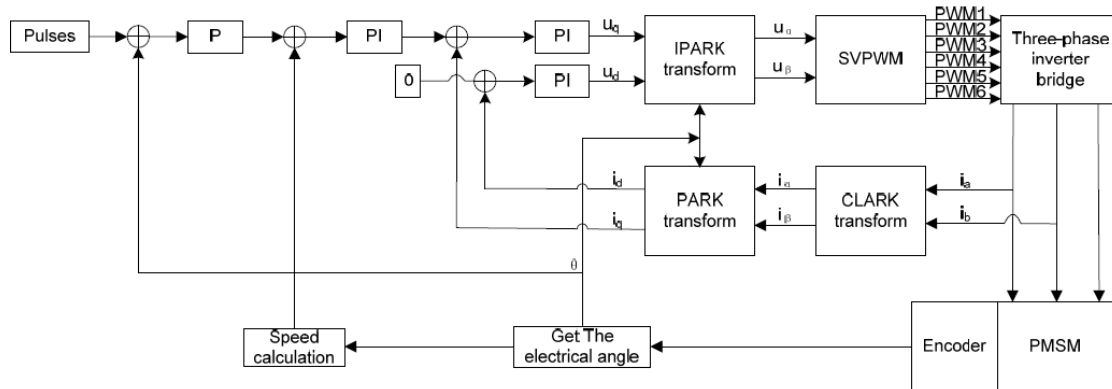

Fig. 2. Vector Control Block Scheme [11]

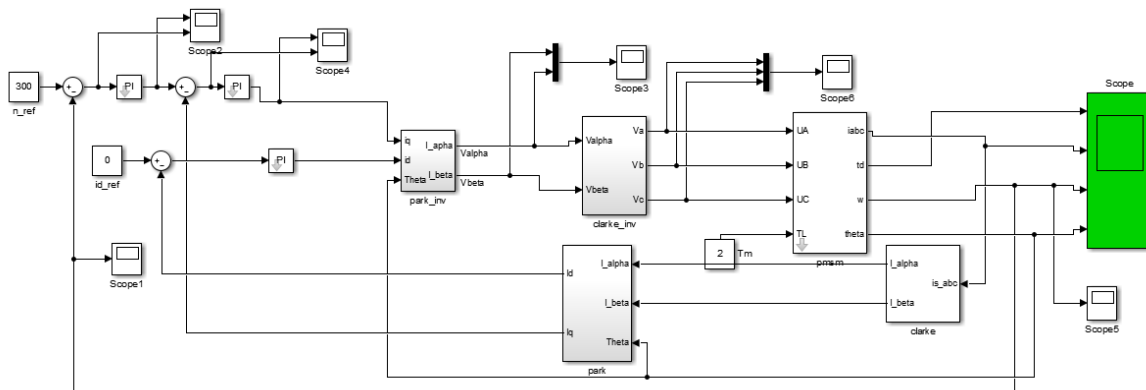

Fig. 3. PMSM FOC Model in Simulink

Figure 3 shows the simulation block diagram. Ziegler–Nichols method is a technique used in PID tuning to find ideal parameters. Method find these parameters by trial and error. The steps to use this method is as follows.

- The I and D gains are first set to zero.
- The "P" gain is increased until it reaches the "critical gain"  $K_{cr}$  at which the output of the loop starts to oscillate.
- $K_{cr}$  and the oscillation period  $P_{cr}$  are used to set the gains as shown.

Ziegler-Nichols Method			
Control Type	$K_p$	$K_i$	$K_d$
P	$0.5K_{cr}$	-	-
PI	$0.45K_{cr}$	$K_p P_{cr}/1.2$	-
PID	$0.6K_{cr}$	$K_p P_{cr}/2$	$K_p P_{cr}/8$

The values are given by

$$K_{cr} = 11.11,$$

$$K_p = 0.45 * 11.11 = 5$$

$$K_p * P_{cr} = \tilde{T} = 12$$

$$K_i = \tilde{T} / 1.2 = 10$$

By using the  $P$  and  $I$  parameters that has been calculated above, we ran our simulations and obtained the speed graphic of PMSM as shown below.

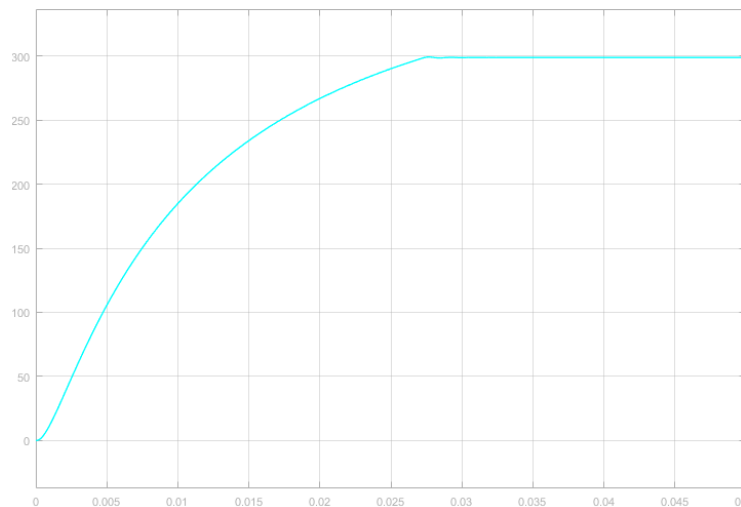

Fig. 4. Motor Mechanical Speed [rad/s]

As seen from the figure, we can control the speed of the PMSM very precisely by using the parameters that we found by using Ziegler-nichols method.

### 3. Conclusions

In this study, speed control of the PMSM has been performed by using Ziegler-Nichols method on Matlab/Simulink software. Ziegler Nichols method has been successful on designing parameters and controlling PMSM speed according to the simulation results.

### References

- [1] <http://empoweringpumps.com/ac-induction-motors-versus-permanent-magnet-synchronous-motors-fuji/>;
- [2] Yun-jie Wu, Guo-fei Li, "Adaptive disturbance compensation finite control set optimal control for PMSM systems based on sliding mode extended state observer" Mechanical Systems and Signal Processing Volume 98, 1 January 2018, pp. 402-414;
- [3] Aishwarya A. Apte, Vrunda A. Joshi, Rahee A. Walambe, Ashwini A. Godbole, "Speed Control of PMSM Using Disturbance Observer" IFAC-PapersOnLine Volume 49, Issue 1, 2016, pp. 308-313;
- [4] Xudong Liu, Chenghui Zhang, Ke Li, Qi Zhang, "Robust current control-based generalized predictive control with sliding mode disturbance compensation for PMSM drives" ISA Transactions;
- [5] O. Ouledaliab, A. Meroufelb, P. Wiraab, S. Bentoubaab, "Direct Torque Fuzzy Control of PMSM based on SVM" Energy Procedia Volume 74, August 2015, pp. 1314-1322;
- [6] J. Jacoba, A. Chitrab, "Field Oriented Control of Space Vector Modulated Multilevel Inverter fed PMSM Drive" Energy Procedia Volume 117, June 2017, pp. 966-973;
- [7] Duarte Valério, José Sá da Costa, "Tuning of fractional PID controllers with Ziegler-Nichols-type rules" Signal Processing, Volume 86, Issue 10, October 2006, pp. 2771-2784;

- [8] J. Jacoba, A.Chitrab, "Field Oriented Control of Space Vector Modulated Multilevel Inverter fed PMSM Drive" Energy Procedia Volume 117, June 2017, pp. 966-973;
- [9] W. Lina, X. Kun, L. De Lillo, L. Empringham, P. Wheeler, "PI controller relay auto-tuning using delay and phase margin in PMSM drives", Chinese Journal of Aeronautics Volume 27, Issue 6, December 2014, pp. 1527-1537;
- [10] Qiang Song, Chao Jia, " Robust Speed Controller Design for Permanent Magnet Synchronous Motor Drives Based on Sliding Mode Control" Energy Procedia Volume 88, June 2016, pp. 867-873;
- [11] <http://www.mstarlabs.com/control/znrule.html>.