

USING A NEW CAD-CAE DESIGN METHOD FOR DESIGNING A MICROHYDROPOWER SYSTEM FOR HYDRO ENERGY RECOVERY

Eugen MARIN^{1,*}, Dragoş MANEA¹, Iulian-Florin VOICEA¹, Liliana DUMITRESCU²

¹ National Institute of Research - Development for Machines and Installations Designed to Agriculture and Food Industry - INMA Bucharest / Romania

² National Institute of Research & Development for Optoelectronics / INOE 2000 – Subsidiary Hydraulics and Pneumatics Research Institute / IHP, Bucharest / Romania

Abstract: *This paper presents a CAD-CAE design method of a welded metal sub-assembly that is a main component of a microhydropower system, which will recover hydro energy and transform it into electrical energy needed to operate aeration systems in fish ponds, under the conditions of efficient use of exploitable resources in animal husbandry. This research proposes a new approach to 3D modeling and advocates for the promotion of the role of microhydropower systems to minimize CO₂ emissions in Romania's economy.*

Keywords: CAD-CAE design, microhydropower system, renewable energy

1. Introduction

Climate change is a danger to future generations in the modern world because it causes great damage to economic growth and industrialization [1]. Fossil fuels are considered the main source of global warming and environmental degradation that has occurred with the growth of the global population and the economies of industrially developed countries [2]. Many countries around the world have policy initiatives to switch from conventional fossil fuel-based energy systems to cleaner and more sustainable alternatives [3]. In the world, policy makers leading developed economies can promote sustainable development, mitigate climate change and ensure long-term sustainable electricity production [4]. Internationally, renewable energy is becoming more and more promoted because it is cheaper, cleaner and more efficient than traditional forms of energy. The most important is hydropower, as a source of renewable energy, considered green energy because it is produced in a way that is beneficial to the environment [5].

In the context of the corresponding global need to increase the share of renewable generation in the energy mix, small-scale hydropower systems offer a significant opportunity to move closer to this goal [6].

The design of a micro hydropower system using CAD-CAE concepts and tools based on the application of parameterization methods that are technically and economically viable is very important to ensure sustainable operation [7]. In the design of hydropower generators, which bear multiple forces from various sources during operation, finite element analysis is used for three-dimensional (3D) modeling, with the aim of studying their performance and static properties [8]. Modern design methods are used, for example, for one-way simulation of three-dimensional fluid-structure interaction to analyze the performance of a static Savonius hydrokinetic turbine at different rotor positions [9].

In practical applications, in engineering, methods of analyzing deformable mechanical systems are used, which are based on numerical techniques related to the finite element method (FEM) as well as on the application of classical methods used in analytical mechanics [10].

2. Materials and methods

In the framework of a research project, a microhydropower system was designed, which will recover hydro energy and transform it into electricity necessary for the operation of aeration systems in fish ponds, under the conditions of efficient use of exploitable resources from animal husbandry. Aeration

brings numerous benefits to aquatic ecosystems. In addition to improving fish habitat, water quality, reducing algae and phosphorus, aeration kills unwanted bacteria, solves the mosquito problem and removes unpleasant odors, all by recirculating water and adding dissolved oxygen.

The main elements that make up the microhydropower system are the following:

- the collection and transfer circuit that includes the system of pipes, valves, the exhaust channel, the water outlet;
- frame, rotor with paddle type blades, transmission guard;
- the speed multiplier, the belt for transmitting the movement to an electrical generator with permanent magnets;
- the electric cables, the controller, the electric energy storage batteries and the inverter for the transformation of the direct voltage electric energy into the 220V alternating voltage electric energy needed to supply the ventilation systems.

Figure 1 shows the 3D geometric model of the microhydropower system, which was CAD designed using SolidWorks software.

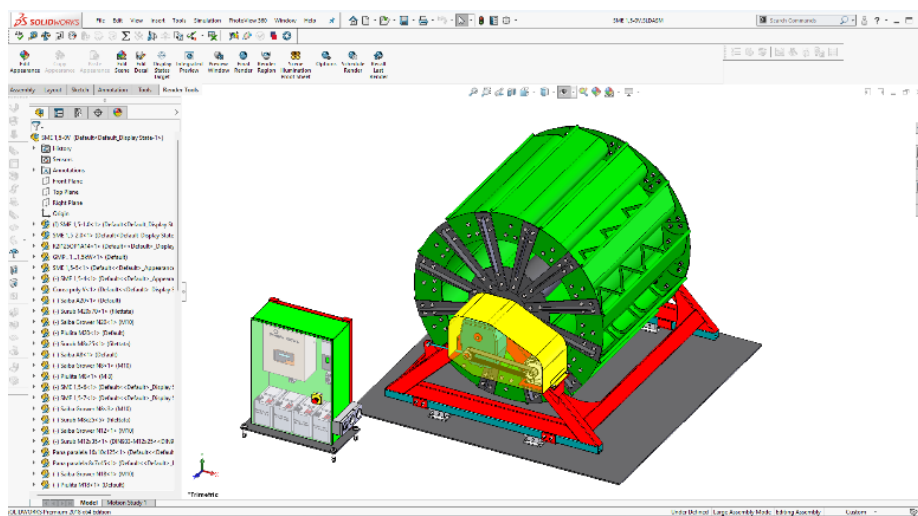

Fig. 1. The 3D geometric model of the microhydropower system

The rotor with paddle-type blades (fig. 2) is the main working organ of a microhydropower system and is intended for the conversion of the kinetic energy of the water flow and its transmission through the kinematic chain to the aggregates producing electricity (multiplier+generator).

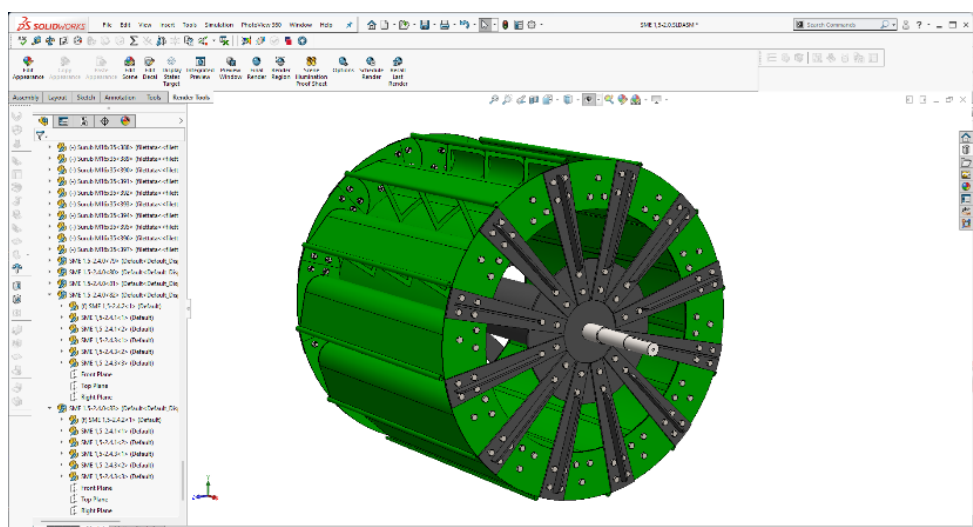

Fig. 2. The rotor with paddle-type blades from the microhydropower system

The blade (fig. 3), a component of the rotor, was designed by assembling from previously defined landmarks, a method called bottom-up design. First, the 3D geometric model was created for each individual component, after which they were assembled using the *Assemblies* module.

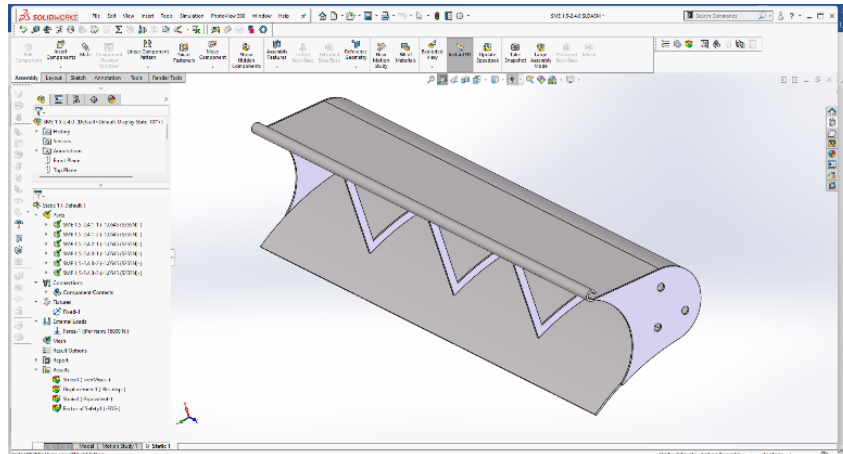

Fig. 3. Component blade of the rotor of the microhydropower system

3. Results

When designing the blade, the static or dynamic loads that will require the microhydropower system were taken into account. When checking the resistance to static stresses, in order to identify the more stressed areas and remove the excess material, the Simulation module was used, which is fully integrated in SolidWorks, which involved importing the geometry of the 3D model made, defining the material, defining the appropriate restrictions for the discretizations, running the program for analysis calculation of Von Mises stress, displacement, relative elongation, safety factor and visualization of the results in the form of diagrams.

The structural analysis with the CAD-CAE method involved the following operations [11, 12]:

- selecting static as the analysis type, solid for the discretization type and the FFEPlus solver (fig. 4).

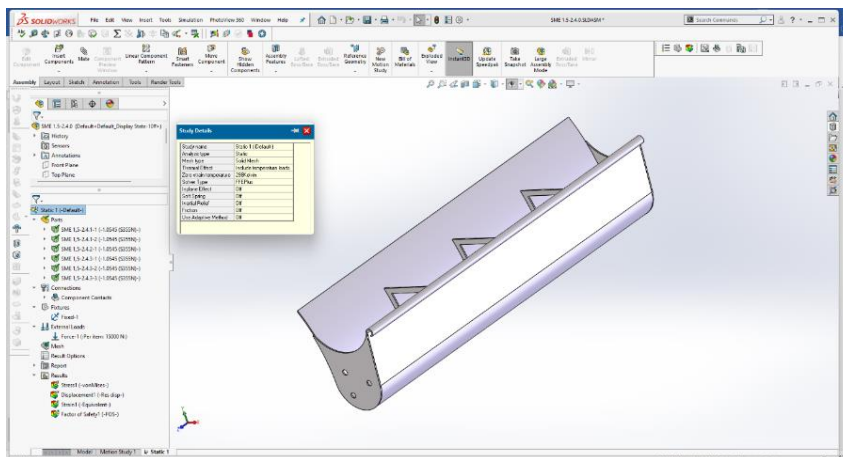

Fig. 4. Static option as analysis type, solid for discretization type and FFEPlus solver

- selecting the material from the SolidWorks library and automatically assigning these properties to each component reference (as shown in Table 1).

Table 1: Properties of selected materials

Material name:	1.0545 (S355N)	1.0503 (C45)	AISI 4340 Steel, normalized
Model type:	Linear Elastic Isotropic	Linear Elastic Isotropic	Linear Elastic Isotropic
Default failure criterion:	Max von Mises Stress	Max von Mises Stress	Max von Mises Stress
Yield strength:	2.75e+08 N/m ²	5.8e+08 N/m²	7.1e+08 N/m²
Tensile strength:	4.5e+08 N/m ²	7.5e+08 N/m²	1.11e+09 N/m²
Elastic modulus:	2.1e+11 N/m ²	2.1e+11 N/m²	2.05e+11 N/m²
Poisson's ratio:	0.28	0.28	0.32
Mass density:	7800 kg/m ³	7800 kg/m³	7850 kg/m³
Shear modulus:	7.9e+10 N/m ²	7.9e+10 N/m²	8e+10 N/m²
Thermal expansion coefficient:	1.1e-05 /Kelvin	1.1e-05 /Kelvin	1.23e-05 /Kelvin

- applying the appropriate load. In accordance with the real mode of operation (operational), the simulation scenario was adapted accordingly. The load was applied at the points corresponding to the mode of operation shown in table 2.

Table 2: Applying the appropriate load

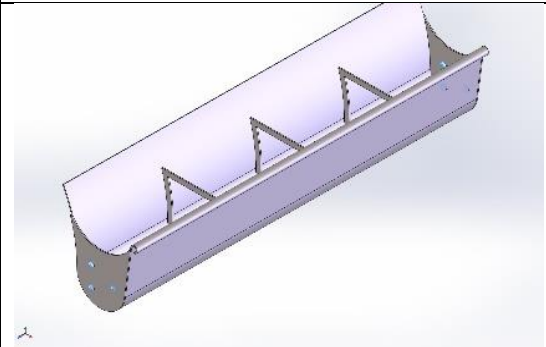
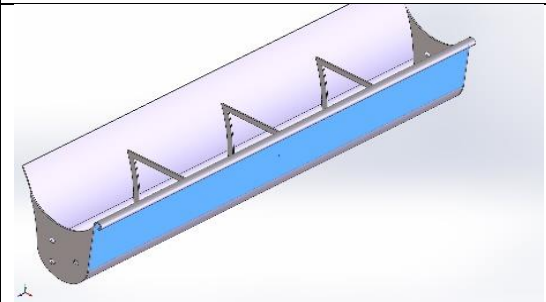
Fixture name	Fixture Image	Fixture Details															
Fixed-1		<table border="1" style="width: 100%;"> <tr> <td>Entities:</td> <td colspan="3">6 face(s)</td> </tr> <tr> <td>Type:</td> <td colspan="3">Fixed Geometry</td> </tr> </table>				Entities:	6 face(s)			Type:	Fixed Geometry						
Entities:	6 face(s)																
Type:	Fixed Geometry																
Resultant Forces																	
Components		X	Y	Z	Resultant												
Reaction force (N)		14867.3	-1990.7	-0.00219727	15000												
Reaction Moment (N.m)		0	0	0	0												
Load name	Load Image	Load Details															
Force-1		<table border="1" style="width: 100%;"> <tr> <td>Entities:</td> <td colspan="3">1 face(s)</td> </tr> <tr> <td>Type:</td> <td colspan="3">Apply normal force</td> </tr> <tr> <td>Value:</td> <td colspan="3">15000 N</td> </tr> </table>				Entities:	1 face(s)			Type:	Apply normal force			Value:	15000 N		
Entities:	1 face(s)																
Type:	Apply normal force																
Value:	15000 N																

- using the "*meshing procedure*" to break down the model into discrete elements (table 3). In general, a finite element model is defined by a mesh, which is completely made of a geometric arrangement of elements and nodes. Nodes represent points, where features such as displacements are calculated.

Table 3: Break down the model into discrete elements

Total Nodes	10651
Total Elements	30708
Maximum Aspect Ratio	19.68
% of elements with Aspect Ratio < 3	2.95
% of elements with Aspect Ratio > 10	0.466
Time to complete mesh(hh:mm:ss):	00:00:11

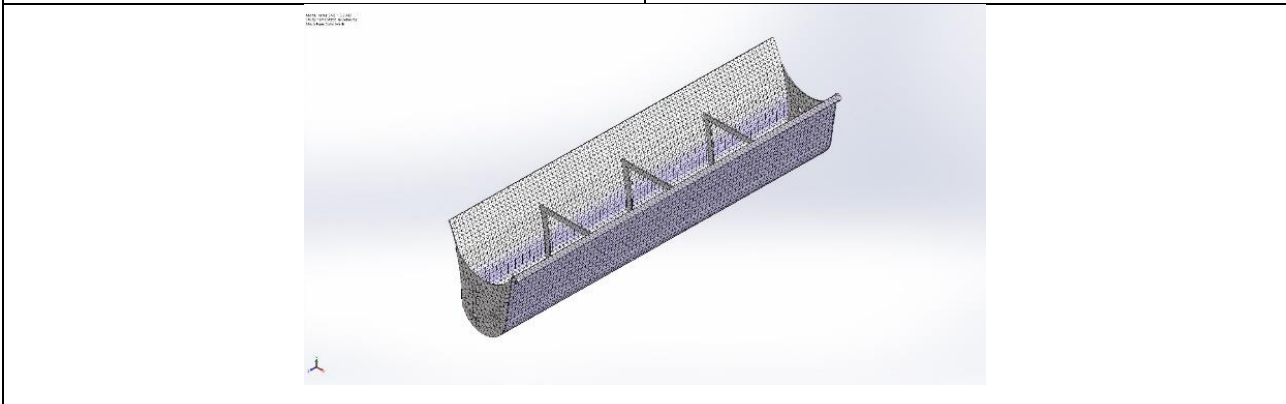

- running the analysis study to calculate stress, factor of safety and displacement, which is based on geometry, material, load, constraint conditions and discretization type. The results can be viewed in table 4.

Table 4: Results of analysis study 1 (material S355N)

Name	Type	Min	Max
Stress1	VON: von Mises Stress	0.000e+00 N/m ² Node: 9944	2.271e+08 N/m ² Node: 23
Displacement1	URES: Resultant Displacement	0.000e+00 mm Node: 1	2.568e+00 mm Node: 1012
Strain1	ESTRN: Equivalent Strain	0.000e+00 Element: 29255	1.216e-03 Element: 1716
Factor of Safety1	Automatic	1.211e+00 Node: 23	1.000e+16 Node: 9944

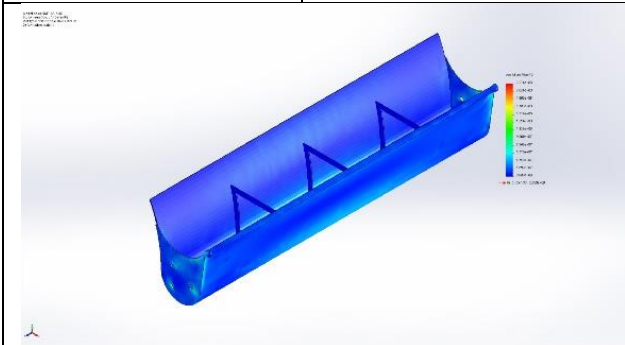

Static 1-Stress-Stress1

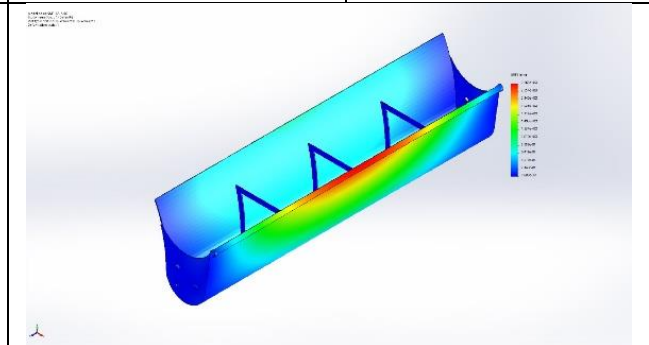

Static 1-Displacement-Displacement1

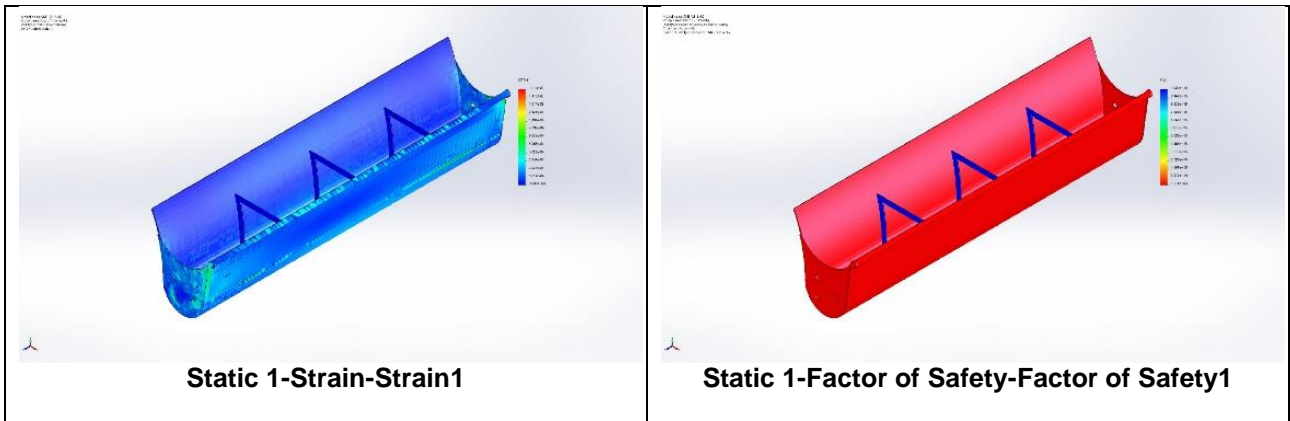

After running Analysis Study 2, the results can be viewed in Table 5.

Table 5: Results of analysis study 2 (material C45)

Name	Type	Min	Max
Stress1	VON: von Mises Stress	0.000e+00 N/m ² Node: 9944	2.271e+08 N/m ² Node: 23
Displacement1	URES: Resultant Displacement	0.000e+00 mm Node: 1	2.568e+00 mm Node: 1012
Strain1	ESTRN: Equivalent Strain	0.000e+00 Element: 29255	1.216e-03 Element: 1716
Factor of Safety1	Automatic	2.554e+00 Node: 23	1.000e+16 Node: 9944

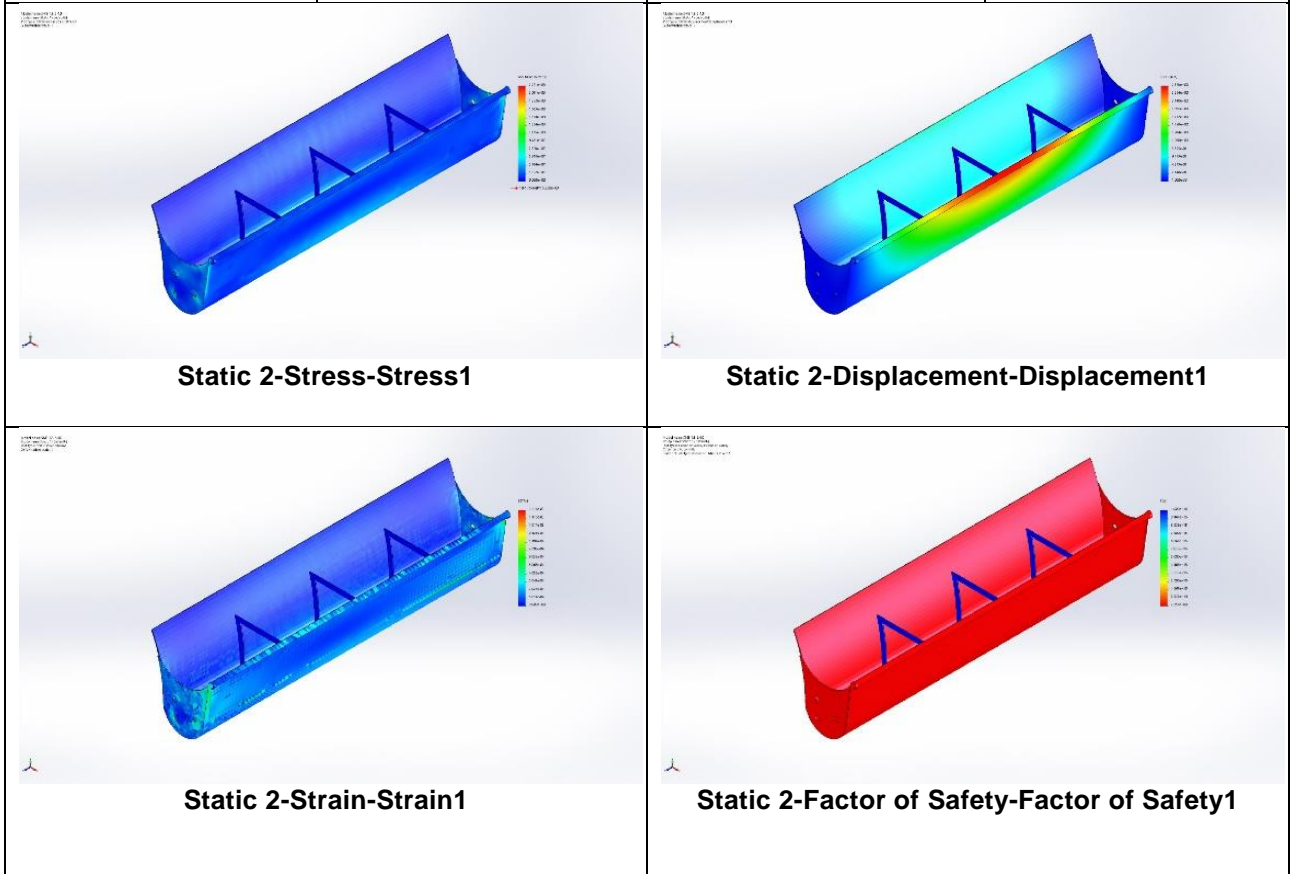

After running Analysis Study 3, the results can be viewed in Table 6.

Table 6: Results of analysis study 3 (material AISI 4340)

Name	Type	Min	Max
Stress1	VON: von Mises Stress	0.000e+00 N/m ² Node: 9944	2.199e+08 N/m ² Node: 23
Displacement1	URES: Resultant Displacement	0.000e+00 Element: 29255	1.269e-03 Element: 1716
Strain1	ESTRN: Equivalent Strain	0.000e+00 Element: 29255	1.269e-03 Element: 1716
Factor of Safety1	Automatic	3.228e+00 Node: 23	1.000e+16 Node: 9944

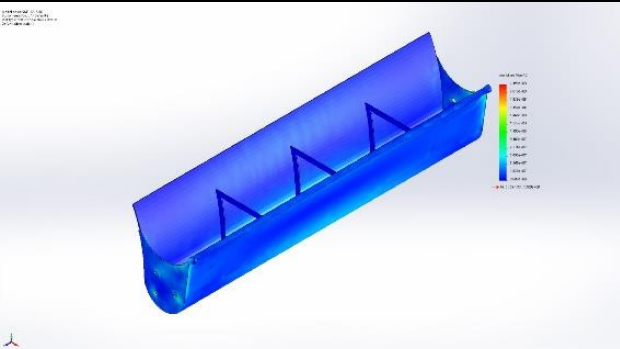
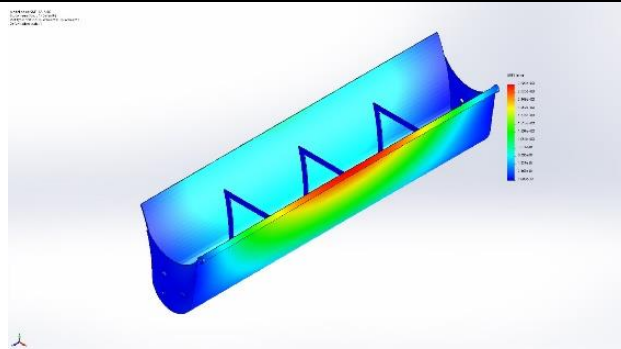
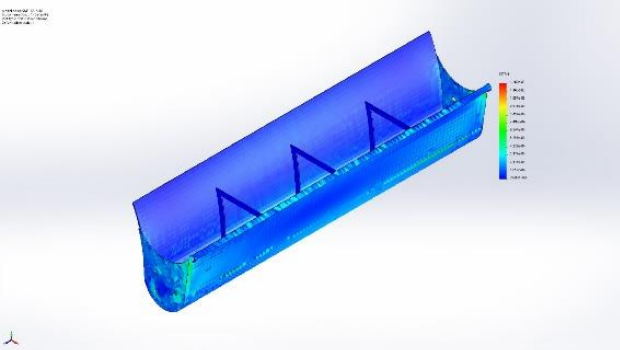
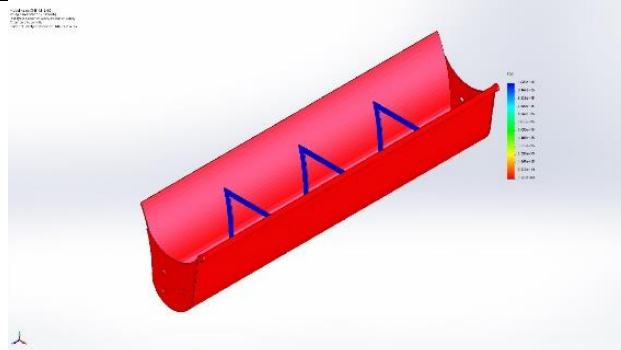
 <p>Static 3-Stress-Stress1</p>	 <p>Static 3-Displacement-Displacement1</p>
 <p>Static 3-Strain-Strain1</p>	 <p>Static 3-Factor of Safety-Factor of Safety1</p>

The results of the analysis on technical-economic criteria in the choice of the metal material from which the blade is made are presented in table 7.

Table 7: The results of the analysis on technical-economic criteria

Name	Measure unit	Value		
		Material 1 1.0545 (S355N)	Material 2 1.0503 (C45)	Material 2 AISI 4340 Steel. normalized
Safety factor	-	1.21	2.55	3.22
Mass	kg	28.55	28.55	28.55
Cost price	lei/kg	4.98	25.57	33.01
Cost price / Safety factor	-	117.41	286.30	292.70

The cost price was obtained by averaging the prices of at least three offers (print screen from specialized websites, offers received by email, photos of offers identified on the shelf, etc.).

In figure 5, the indicators obtained for the choice of the metal material from which the blade of the microhydropower system is made are graphically represented.

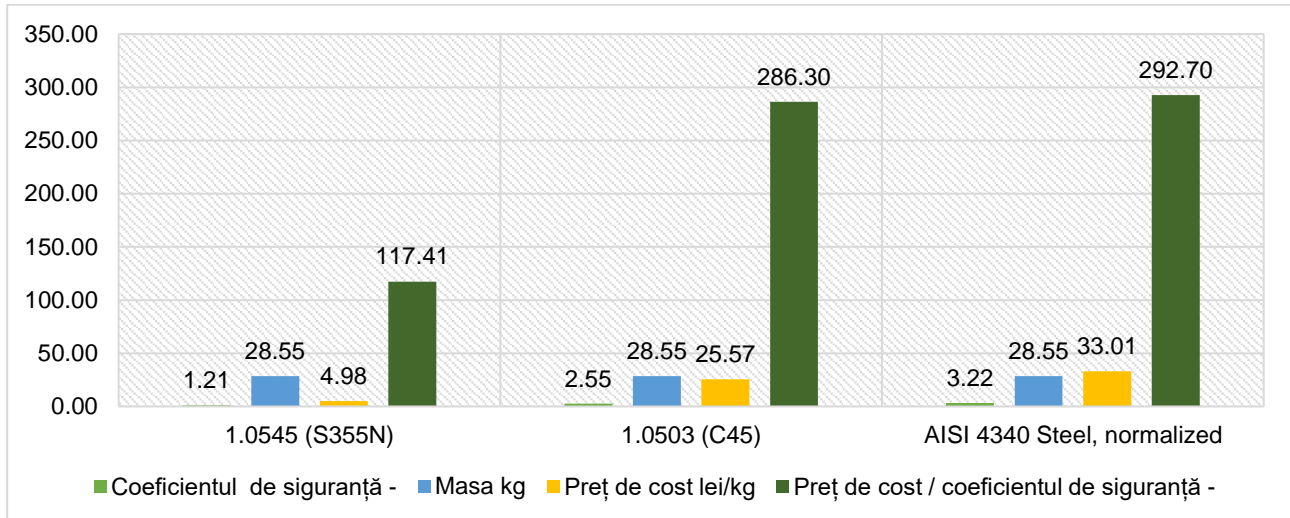

Fig. 5. Graphic representation of the indicator obtained for the choice of the metal material from which the blade of the microhydropower system is made

The comparison of the indicators in figure 5 led to the choice of the optimal variant (the material S355N was chosen, which has the lowest "Price-cost / Safety coefficient" ratio, which was 117.41). Table 8 shows the chemical properties of the chosen material.

Table 8: Chemical composition % of steel S355NL (1.0546): EN 10025-3-2004

C %	Si %	Mn %	P %	S %	Al %	Cr %	Cu %	Mo %	N %	Nb %	Ni %	Ti %	V %
max 0.18	max 0.50	0.90 - 1.65	max 0.025	max 0.020	mind. 0.0200	max 0.30	max 0.55	max 0.10	max 0.015	max 0.050	max 0.50	max 0.05	max 0.12

EN10025-3 S355NL grade is a normalized weldable and a fine grain structural steel. It has greater yielding strength at a room temperature of about 355 MPA at 16mm and falling temperature at 250 mm to 250 MPA. Knowledge of the chemical properties of the chosen material helped in the choice of corrosion protection by using an epoxy primer rich in activated zinc and a polyurethane paint which are designed for the protection of steel in highly corrosive atmospheric conditions in full compliance with Directive 2004/42/EC.

4. Conclusions

- Analysis by the finite element method, represents a modern method for the study of metallic structures, allowing the determination of Von Mises stress, displacement, relative elongation and safety factor;
- The technical-economic indicator (manufacturing cost per unit of safety coefficient) proposed by the authors for the analysis of the choice of the optimal variant, contributes to the reduction of the design validation time and to the reduction of manufacturing costs;
- The CAD-CAE design method of a welded metal subassembly of the microhydropower system advocates for the promotion of the role of microhydropower systems in order to minimize CO₂ emissions in the Romanian economy.

Acknowledgments

The results presented in this article were obtained with the support of MADR through the "Sectoral Plan - ADER 2026", financing contract no. 13.1.1 / 17.07.2023, ADER project 13.1.1. *Research on increasing profitability in aquaculture farms by introducing valuable species with the implementation of specific aquaculture, animal husbandry and agricultural technologies - the realization of the integrated aquaculture farm*, managed by the The Research and Development Institute for Aquatic Ecology, Fishing and Aquaculture – Galati.

References

- [1] Magraw, D. and M. Siemes. "The right to a healthy environment, the rights of future generations, and climate change." *The Fletcher Forum of World Affairs* 47, no. 1 (2023): 87-96.
- [2] Wang, J. and W. Azam. "Natural resource scarcity, fossil fuel energy consumption, and total greenhouse gas emissions in top emitting countries." *Geoscience Frontiers* 15, no. 2 (2024): 101757.
- [3] Adelekan, O.A., B.S. Ilugbusi, O. Adisa, O.C. Obi, K.F. Awonuga, O.F. Asuzu, and N.L. Ndubuisi. "Energy transition policies: a global review of shifts towards renewable sources." *Engineering Science & Technology Journal* 5, no. 2 (2024): 272-287.
- [4] Gayen, D., R. Chatterjee, and S. Roy. "A review on environmental impacts of renewable energy for sustainable development." *International Journal of Environmental Science and Technology* 21, no. 5 (2024): 5285-5310.
- [5] Mohsin, M., D. Orynassarov, M.K. Anser, and Y. Oskenbayev. "Does hydropower energy help to reduce CO2 emissions in European Union countries? evidence from quantile estimation." *Environmental Development* 45 (2023): p.100794.
- [6] Alapfy, B., N.F. Gamarra, and N. Rüther. "Towards Hydraulic Design Optimization of Shaft Hydropower Plants: A 3D-CFD Application Based on Physical Models." *Water* 16, no. 19 (2024): 2790.
- [7] Dolmatov, S., V. Tsubiks, O. Zhadan, A. Scherbakov, A. Sayfutdinova, and R. Sakhapov. "Increasing the efficiency of design in CAD CAE systems based on the application of parametrization methods." Paper presented at the IV International Conference on Agricultural Engineering and Green Infrastructure Solutions (AEGIS-IV 2024), Tashkent, Uzbekistan, March 28-30, 2024. *BIO Web of Conferences* 105 (2024): 05010.
- [8] Rondon, D., S. Pääjärvi, J.O. Aidanpää, R. Gustavsson, and P. Jeppsson. "Three-Dimensional Modeling for Mechanical Analysis of Hydropower Generators with Floating Rotor Rim." *Machines* 12, no. 4 (2024): 268.
- [9] Yazik, M.H.M., M.H. Zawawi, A.N. Ahmed, L.M. Sidek, H. Basri, and F. Ismail. "One-way fluid structure interaction analysis of a static savonius hydrokinetic turbine under different velocity and surface roughness with different blade materials." *Ocean Engineering* 291 (2024): 116373.
- [10] Vlase, S., M. Marin, and I. Negrean. "Finite element method-based elastic analysis of multibody systems: A review." *Mathematics* 10, no. 2 (2022): 257.
- [11] Cârdei, P. "Applications of finite element structural analysis in the microstructures field and their specific issues." Paper presented at the 16th SGEM 2016 Vienna Green International Scientific Conference, Vienna, Austria, November 2-5, 2016.
- [12] Cristea, O.D., M.G. Matache, M. Mateescu, and E. Marin. "Use of an innovative method for structural analysis of the distribution device used in pneumatic machines for weeding plant sowing." *Annals of the University of Craiova-Agriculture, Montanology, Cadastre Series* 49, no. 2 (2020): 361-366.